

CABINET INSTALLATION INSTRUCTIONS

Thank you for choosing Royston cabinets for your store. As always, we appreciate your business and are proud to have you as a customer.

IMPORTANT: These instructions provide general guidance for the installation of Royston-built cabinets. Your unique project may require some particular steps not included here. Please call **800-334-1766** for further assistance.

IMPORTANTE: Esta guía provee instrucciones generales para la instalar los gabi-netes Royston. Algunos de los pasos para algún proyecto especial de instalación podrían no estar incluidos. Favor llamar al 800-334-1766 para guía adicional.

RECOMMENDED TOOL LIST

1. Cordless Drill And Fastener Drive Bits
2. Level - 24" Minimum
3. Tape Measure
4. Rubber Mallet / Dead Blow Hammer
5. Pry Bar
6. Large Flat Head Screw Driver
7. Vise-Grips (Needle Nose)
8. Bar Clamps
9. Socket Set
10. Caulk Gun (Optional)
11. Safety Glasses
12. Gloves

LISTA RECOMENDADA DE HERRAMIENTAS:

1. Taladro inalámbrico y brocas de sujeción
2. Nivel – Mínimo de 24 pulgadas
3. Cinta de medir
4. Mazo de caucho / Martillo de golpe seco
5. Barra de palanca
6. Destornillador grande de cabeza plana
7. Agarraderas de prensa (Punta de aguja)
8. Abrazaderas de barra
9. Juego de alvéolos
10. Pistola de calafateo (Opcional)
11. Gafas de seguridad
12. Guantes



Step 1. CONFIRM that the carrier's bill of lading matches the container and products unloaded from the delivery truck. Inspect the outside of each container for any indication of potential concealed damage. Carefully and clearly note any and all damage on the freight bill before signing.

Paso 1. CONFIRME que el reconocimiento del transportador corresponde al contenedor y a los productos descargados del camión. Una vez que el producto es retirado del camión, inspeccione la parte exterior de cada contenedor para identificar cualquier posible daño oculto. Anote claramente todos los daños en el certificado de carga antes de firmar.



Step 2. REVIEW entire contents of envelope titled "Instructions Enclosed". Keep this important information in a safe and secure place as you will need to refer to it often during the installation process.

Paso 2. REVISE el contenido total del sobre de "instrucciones adjuntas". Mantenga esta información importante en un lugar seguro ya que frecuentemente necesitará referirse a la misma durante la instalación.

CABINET INSTALLATION INSTRUCTIONS



Step 3. CLEAR the installation area to ensure project continues safely and easily.

Paso 3. Despeje el área de instalación—un área limpia de trabajo hace más fácil y seguro su proyecto de instalación.



Step 4. UNCRATE all cabinets and move to the installation area. Arrange everything according to counter layout. Please note: **DO NOT** remove drawings attached to cabinets until installation is complete.

Paso 4. Desempaque los gabinetes y llévelos hacia el área de instalación. Dispóngalos de acuerdo con la colocación del mostrador. NOTA: No retire las ilustraciones adheridas a los gabinetes hasta que la instalación esté terminada.



Step 5. CHECK that any loose parts such as fillers and hardware are accounted for and stored separately from packaging materials. These items are used in multiple areas during installation and are shipped in bulk. **BE CAREFUL NOT** to lose loose parts when disposing of any packaging material.

Paso 5. Es importante encontrar todas las partes sueltas (reellenos de gabinete, ferretería miscelánea, etc.). Estos artículos son usados en multiples áreas y usualmente despachados en cantidad. **NO** pierda estos artículos cuando deseche el material de empaque.



Step 6. SCREW cabinet levelers clockwise until flush with bottom of base.

Paso 6. Después de desempacar los gabinetes, atornille los niveladores en el sentido de las manecillas del reloj hasta emparejarlos con la parte inferior de la base.



Step 7. If using stainless steel cabinet legs, thread clockwise into base corners until tight. Then, adjust leg to minimum height position. If using skirts, adjust legs to 6 1/2" (min) from the bottom of cabinet.

Paso 7. Si está usando patas de gabinete de acero inoxidable, aterraje en el sentido de las manecillas del reloj en las esquinas de la base hasta que estén ajustadas. Luego, ajuste la pata a la posición de mínima altura. Si está usando guardapiés, ajuste las patas a 6 pulgadas y media (mínimo) desde la parte inferior del gabinete.

CABINET INSTALLATION INSTRUCTIONS



8.

Step 8. ARRANGE all cabinets according to provided floorplan.

Paso 8. Disponga los gabinetes de acuerdo con el plan del piso.



9.

Step 9. REMOVE all items from cabinets that may interfere with initial installation such as cabinet bottom shelf, adjustable shelves, fillers, some cup dispensers, and boxes containing cup covers and condiment trays. Move these items to a safe, convenient area outside the installation area. Mark each piece clearly so you can easily return every item to the correct cabinet.

Paso 9. Retire de los gabinetes artículos que pudieran interferir con la instalación (repisa inferior del gabinete, repisas ajustables, rellenos, algunos dispensadores y cajas de recipientes que contienen tapas de recipientes y bandejas de condimentos). Muévalos a un área segura y conveniente. Márquelos para que los pueda retornar al gabinete correcto.



10.

Step 10. LOCATE all possible plumbing or electrical obstructions. Slight modifications to those connections may be required to ensure proper cabinet fit.

Paso 10. Localice posibles obstrucciones de plomería o eléctricas. Se podrían requerir ligeras modificaciones para asegurar un ajuste apropiado de los gabinetes.

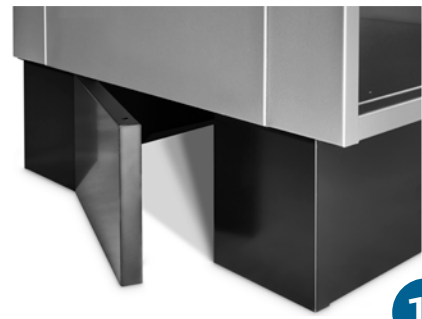

11.

Step 11. REMOVE cabinet base knockouts BETWEEN all cabinets. DO NOT remove knockouts on END cabinets.

Paso 11. Retire los bloques de las bases de los gabinetes que hay entre todos los gabinetes. No retire los bloques de los gabinetes de extremo.

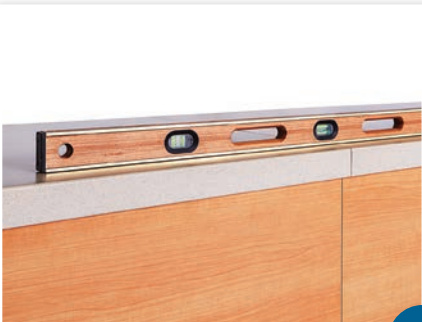

12.

Step 12. START cabinet leveling at floor high point. If no high point is evident, start at the end of a counter and at the wall (if there is one). Use leveling legs to level cabinets side to side and front to back. Continue process until all cabinets are level and properly aligned. Verify all fronts and rears are flush and seams between cabinets are straight.

Paso 12. Comience el nivelado de los gabinetes en el punto más alto del piso. Si no se puede encontrar el punto más alto, comience al final de un mostrador, en la pared si existe una. Use piezas de nivelación para nivelar los gabinetes lado con lado y frente con respaldo. Continúe el proceso hasta que todos los gabinetes estén nivelados y apropiadamente alineados. Verifique que los frentes y los respaldos estén emparejados y que las uniones entre los gabinetes estén derechas.

CABINET INSTALLATION INSTRUCTIONS



13.

Step 13. REFER to site plan in order to identify filler and top locations. Install as required.

Paso 13. Refiriéndose al plan del lugar, identifique las ubicaciones de relleno y de tapas. Instale según sea requerido.

Step 14. FASTEN cabinets together by using tie straps or bolts, see diagram on the left. Please note that cabinet connectors are not included for solid-surface tops or non-Royston manufactured tops.

Paso 14. Sujete los gabinetes juntos—vea la hoja de instrucciones presentada arriba.

TIE STRAP INSTALLATION

1. Line cabinets up with each other, then remove the loose bottom in each cabinet and adjust levelers until top surfaces and fronts align.
2. Check base alignment. If base needs adjustment to be flush with adjacent base, loosen the four bolts on one end and move base as needed, then tighten bolts.
3. Take (part 1) and slide strap (part 4) through slots in both counters, then secure (part 1) to top using (2) particle board screws (part 2).
4. Slide (part 3) on strap and secure to top using (2) particle board screws (part 2).
5. Rotate screw on (part 3) to lock strap (part 4) in place. Tighten screw to lock counters together.

Note: Two tie straps should be used for each cabinet joint; one in the front and one in the back.

BOLTING CABINETS TOGETHER

Note: Bolting cabinets together is recommended for permanent installation, but if you have a tendency to rearrange counters from time to time, you may want to exclude this operation.

1. Double-check cabinet joint to see if top surfaces and fronts align. Adjust if necessary.
2. Drill a 1/4" diameter hole through the ends of the cabinets as close to the front and top as is practical. Bolt cabinets together using a 1/4-20 x 1/2" machine screw and hextite nut.
3. Check base alignment. If base needs adjustment to be flush with adjacent base, loosen the four bolts on one end and move base as needed, then tighten bolts.
4. Drill (2) 1/4" diameter holes in the base ends of the cabinets about 3" up from the bottom and as close to the front and back as is practical. Bolt bases together using (2) 1/4-20 x 1/2" machine screws and hextite nuts.

14.

Connector Attachment (Bottom View)

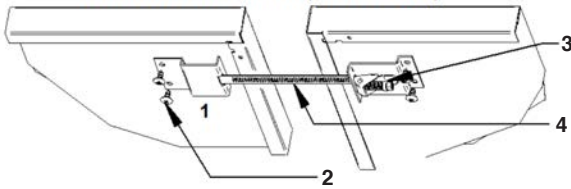

2. Phillips drive #10 x .5 pan head wood screw
3. Tensioning screw
4. Connecting strap (see detail B below)

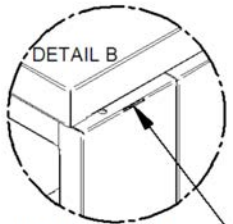

Slots Exist At The Top Of Each Cabinet To Pass The Connecting Straps Through.

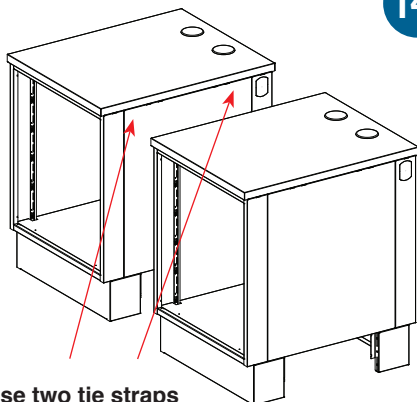

Use two tie straps per cabinet threading thru slots in area shown.

Information in this document is the proprietary property of Royston LLC and is subject to change without notice. Reproduction in any manner without written permission of Royston LLC is absolutely forbidden. Royston LLC reserves the right to make changes in product design or detail and to discontinue any product or material without notice.